

QLA-600-4200-20-10

600~4200MHz, 20dB, 1dB

- | | |
|---|--|
| Features:
* Small Size
* Low Power Consumption | Applications:
* Wireless
* Transmitter
* Laboratory Test |
|---|--|

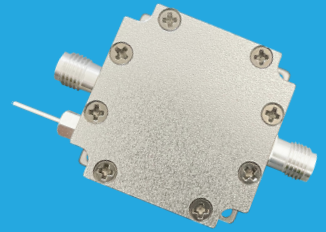

Electrical

Frequency:	600~4200MHz
Gain:	20dB typ.
Gain Flatness:	±2dB typ.
Noise Figure:	1dB typ.
Output Power (P1dB):	21dBm typ.
Input VSWR:	2 typ.
Output VSWR:	2 typ.
Voltage:	+5V DC
Impedance:	50Ω

Absolute Maximum Ratings*1

RF Input Power:	25dBm
Voltage:	+7V

[1] Permanent damage may occur if any of these limits are exceeded.

Mechanical

Size*2:	30*30*15mm 1.181*1.181*0.591in
RF Connectors:	SMA female
Power Supply Connectors:	Feed Through/Terminal Post
Mounting:	4-Φ2.2mm through-hole

[2] Exclude connectors.

Environmental

Operating Temperature: -40~+85°C

Outline Drawings

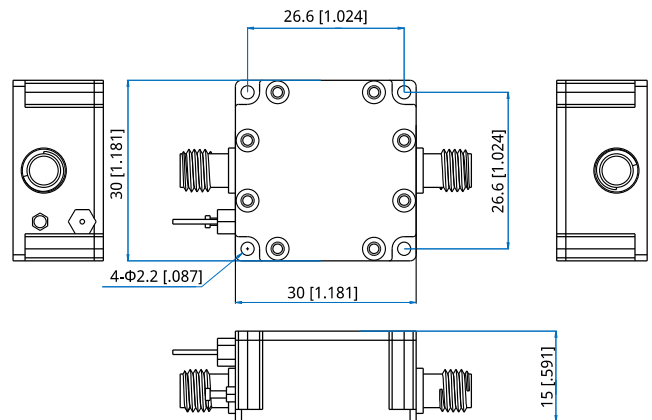

Unit: mm [in]
Tolerance: ±0.2mm [±0.008in]

How To Order

QLA-600-4200-20-10

Customization is available upon request.

Typical Performance Curves

Input VSWR vs. Frequency

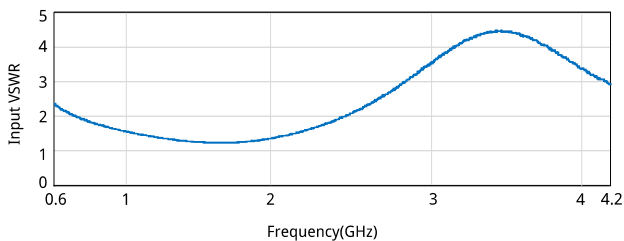

Output VSWR vs. Frequency

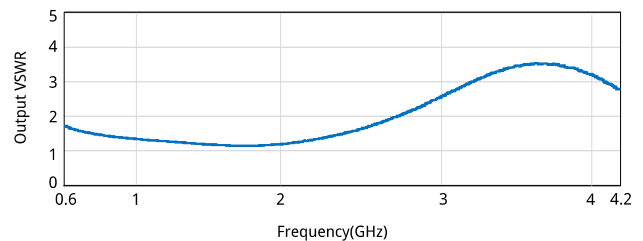

Gain vs. Frequency

